

95/2019

TIP PROJECT: W-5813A

CONTRACT: DM00398

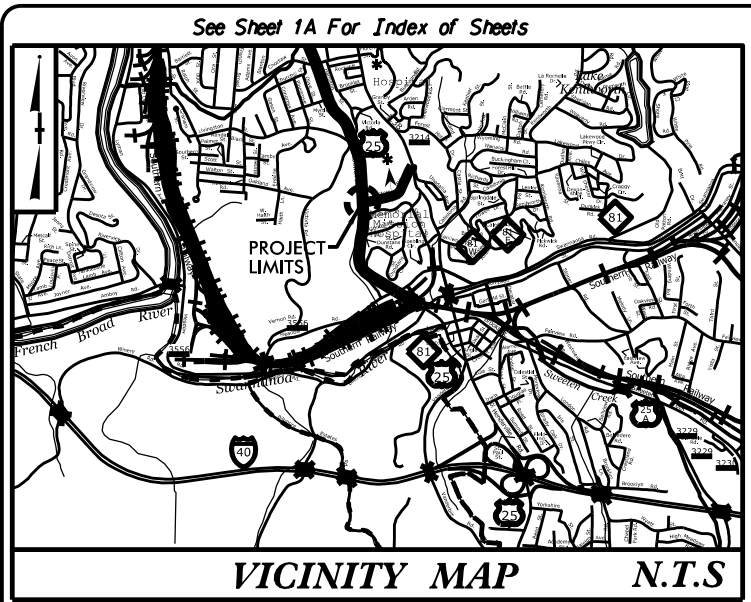

STATE OF NORTH CAROLINA  
DIVISION OF HIGHWAYS

**BUNCOMBE**

LOCATION: US-25 (MCDOWELL ST.) AT DOCTORS DR.

TYPE OF WORK: INSTALLATION OF PEDESTRIAN SIGNALS,  
CURB RAMPS, AND HIGH VISIBILITY CROSSWALKS

STATE	STATE PROJECT REFERENCE NO.	SHEET NO.	TOTAL SHEETS
N.C.	W-5813A	1	
STATE PROJ. NO.	F.A. PROJ. NO.	DESCRIPTION	
48958.3.2	0025044	CONST.	

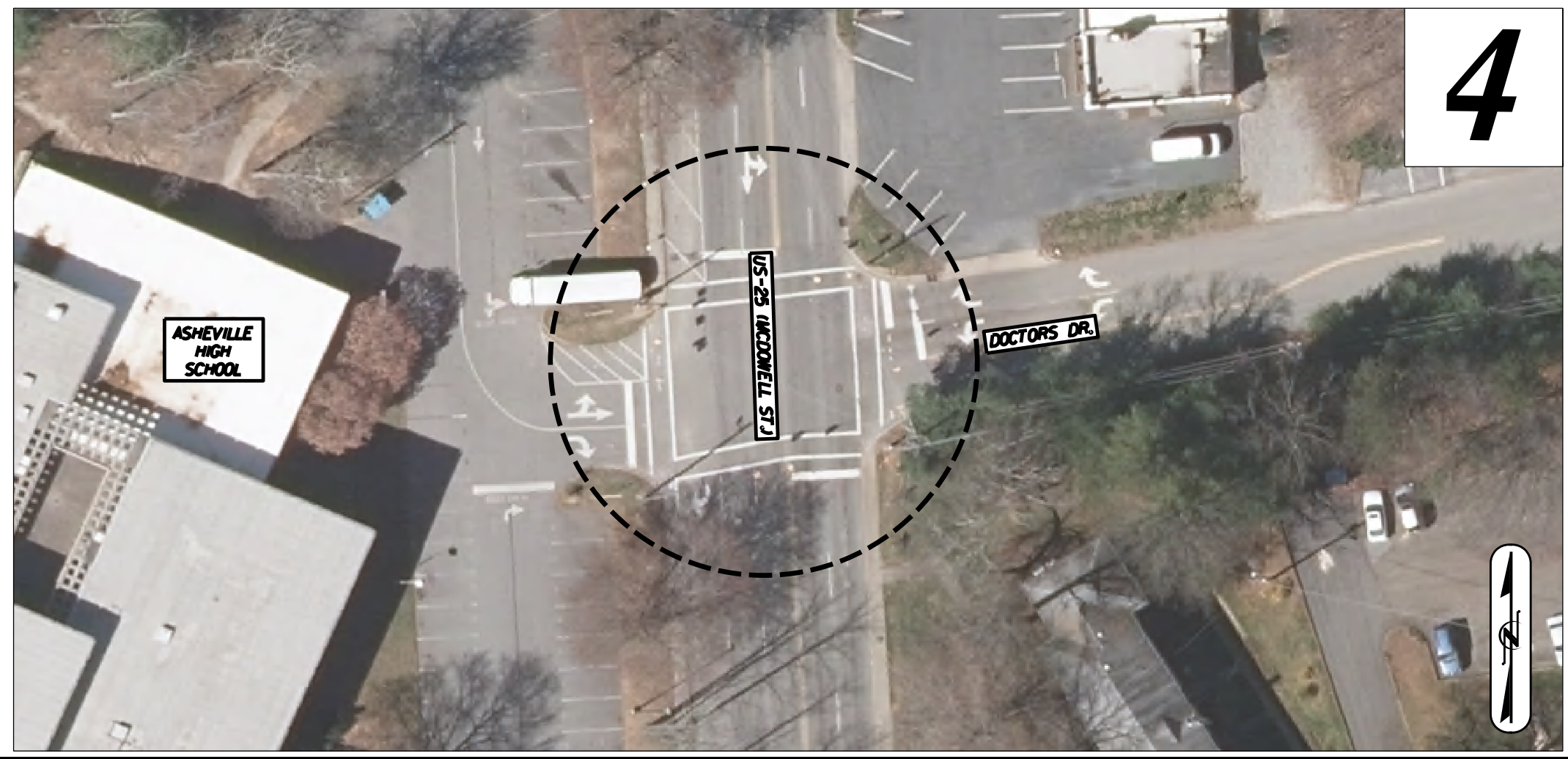

**INCOMPLETE PLANS**  
DO NOT USE FOR R/W ACQUISITION  
DOCUMENT NOT CONSIDERED FINAL  
UNLESS ALL SIGNATURES COMPLETED

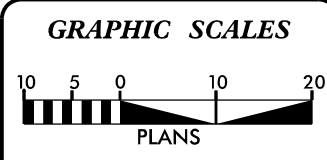

2018 ROADWAY ENGLISH STANDARD DRAWINGS  
EFF. 01-16-2018  
REV.

The following Roadway Standards as appear in "Roadway Standard Drawings" Highway Design Branch - N. C. Department of Transportation - Raleigh, N. C., Dated January, 2018 are applicable to this project and by reference hereby are considered a part of these plans:

STD. NO.	TITLE
DIVISION 6 - ASPHALT PAVEMENTS	
654.01	Pavement Repairs - For Superpave Mix Types
DIVISION 8 - INCIDENTALS	
848.05	Curb Ramp - Proposed Curb and Gutter
848.06	Curb Ramp - Existing Curb and Gutter
DIVISION 12 - PAVEMENT MARKINGS, MARKERS, AND DELINEATION	
1205.01	Pavement Markings - Line Types and Offsets
1205.04	Pavement Markings - Intersections
1205.07	Pavement Markings - Pedestrian Crosswalks

Prepared in the Office of:  
**DIVISION OF HIGHWAYS**  
55 Orange St., Asheville NC, 28801

2018 STANDARD SPECIFICATIONS	
RIGHT OF WAY DATE:	PROJECT ENGINEER
LETTING DATE: NOVEMBER 16, 2022	PROJECT DESIGN ENGINEER

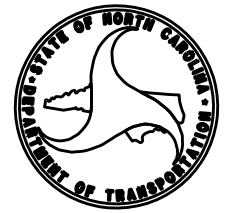

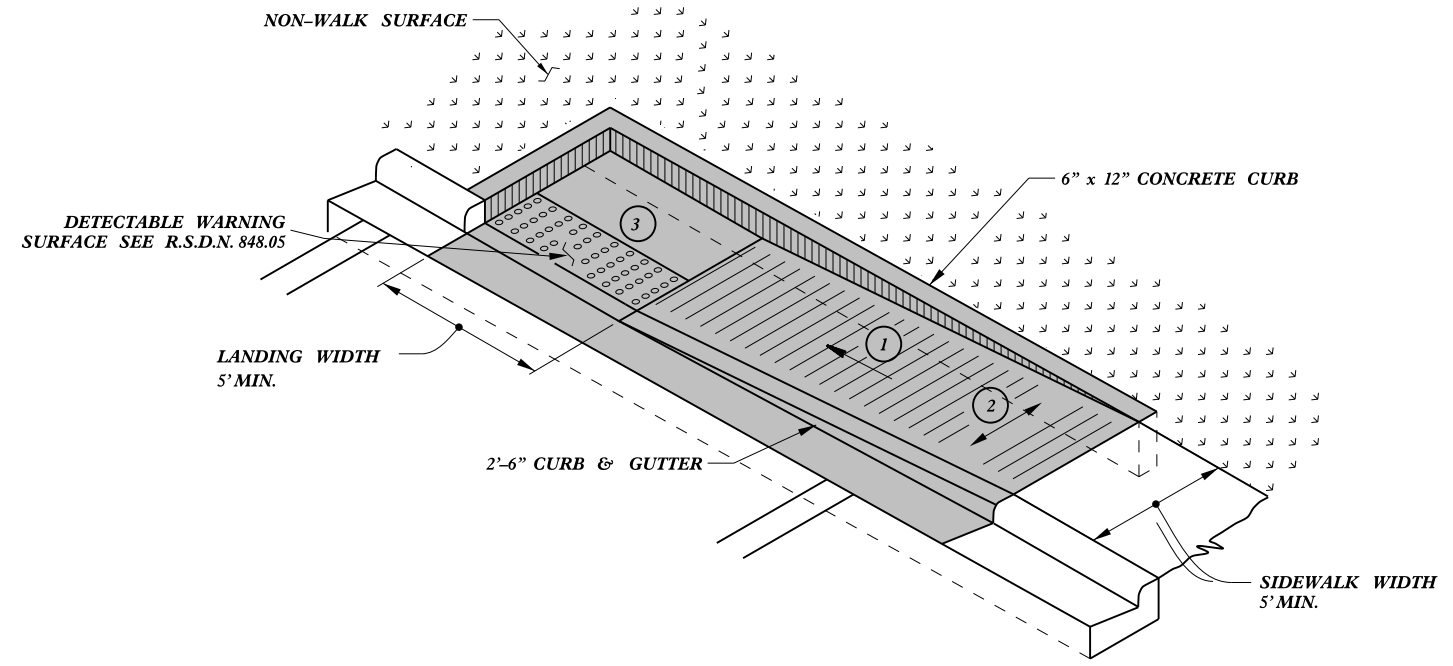

**TYPE 1A**

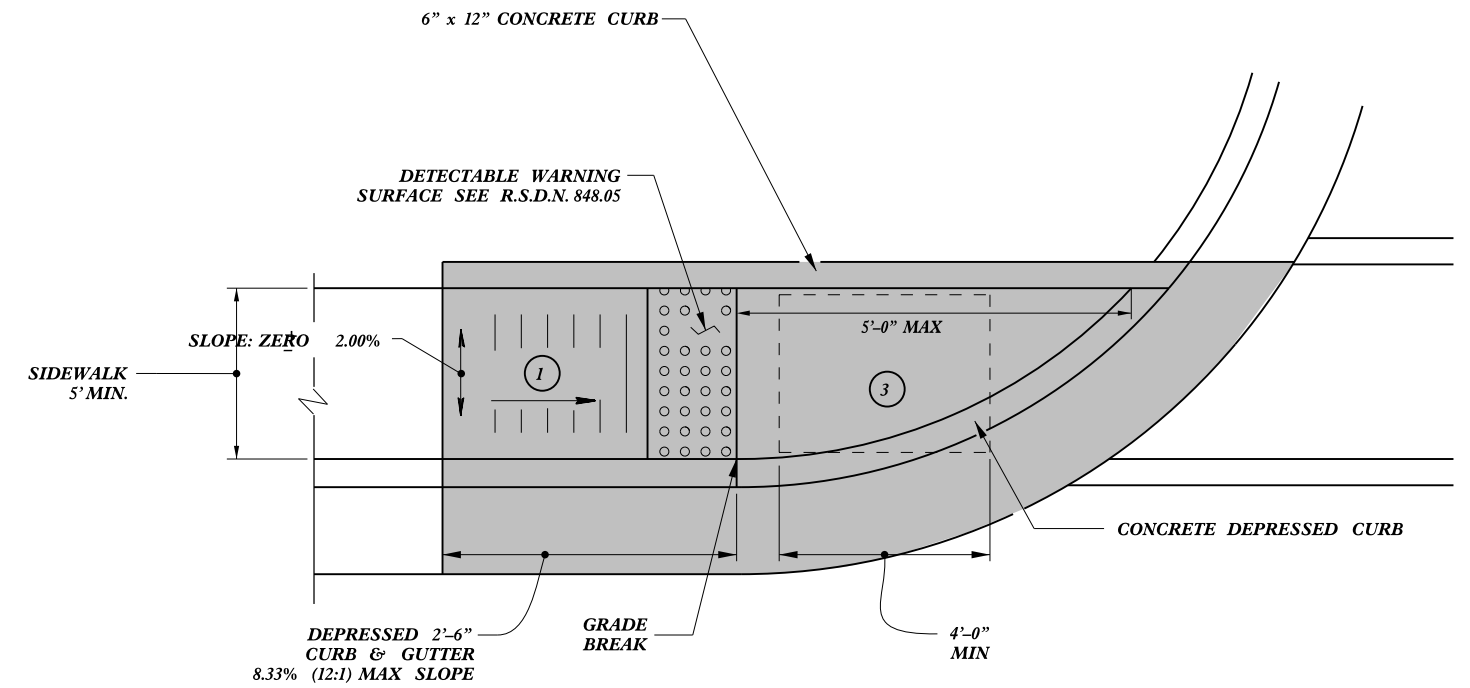

**TYPE 1**

- ① 8.33% (12:1) MAX RAMP SLOPE
- ② CROSS SLOPE: 2.00%
- ③ CURB RAMPS REQUIRE A (4'-0") MINIMUM LANDING WITH A MAXIMUM CROSS SLOPE AND LONGITUDINAL SLOPE OF 2.00% WHERE PEDESTRIANS PERFORM TURNING MANEUVERS. SLOPE TO DRAIN TO CURB.

**PAY LIMITS FOR CURB RAMP**

<b>CONTRACT STANDARDS AND DEVELOPMENT UNIT</b>	
Office 919-707-6950	FAX 919-250-4119
<b>CURB RAMPS</b>	
Directional Ramps	
ORIGINAL BY: J.S. HOWERTON	DATE: 7/7/11
MODIFIED BY:	DATE:
CHECKED BY:	DATE:
FILE SPEC: sstds/2012CurbRamp/CurbRampDetails.dwg	

REFER TO ROADWAY STANDARD DRAWING NUMBER 848.05 SHEET 3 OF 3 FOR ALL RAMP NOTES

23-MAR-2012 15:05 J:\Projects\2012\Standard Drawings\2012 Standard Drawings\Curb Ramp Special Details\Curb Ramp Details.dwg  
 J.Howerton AT 15023750

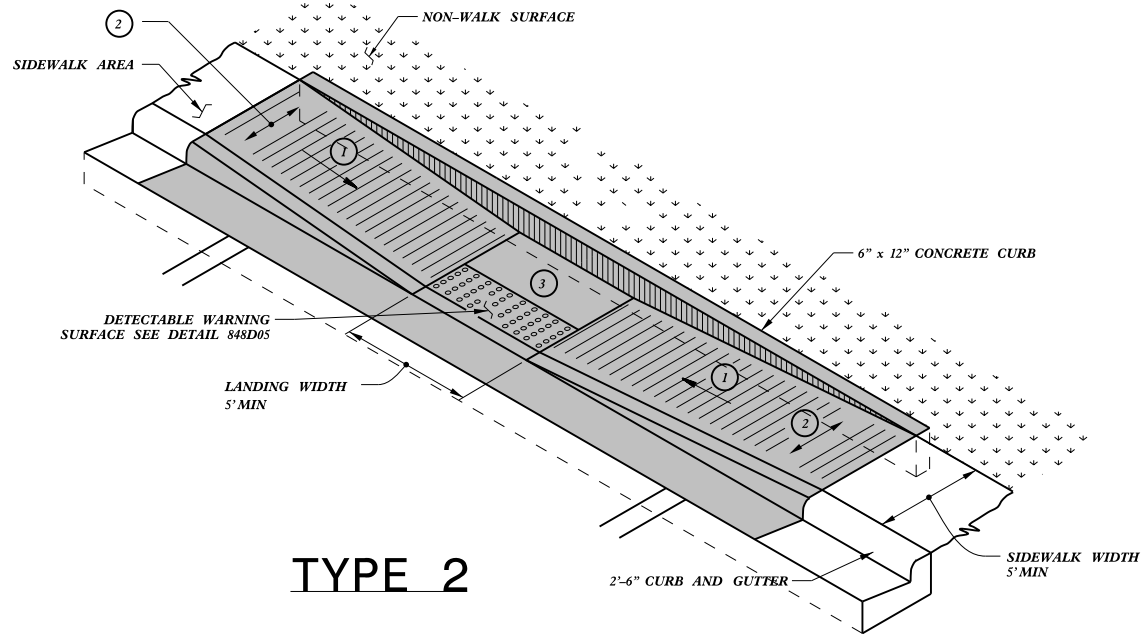

**TYPE 2**

**PAY LIMITS FOR CURB RAMP**

- ① 8.33% (12:1) MAX RAMP SLOPE
- ② CROSS SLOPE: 2.00%
- ③ CURB RAMPS REQUIRE A (4'-0") MINIMUM LANDING WITH A MAXIMUM CROSS SLOPE AND LONGITUDINAL SLOPE OF 2.00% WHERE PEDESTRIANS PERFORM TURNING MANEUVERS. SLOPE TO DRAIN TO CURB.

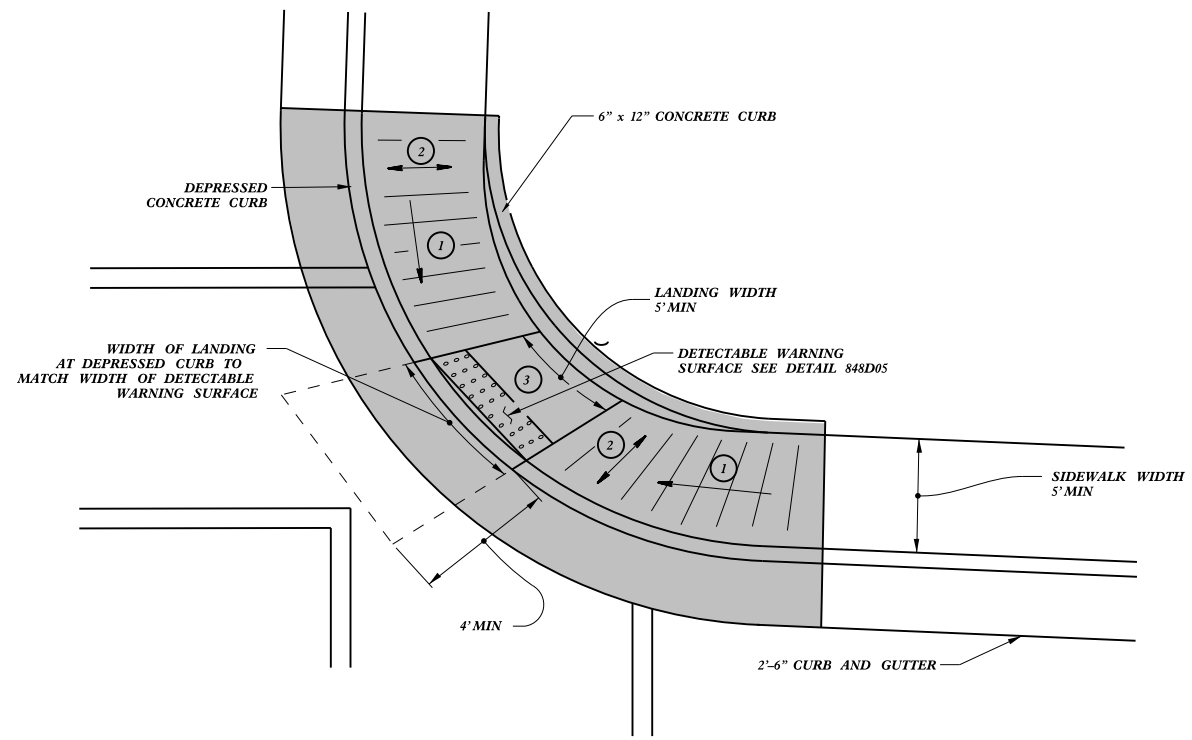

**TYPE 2A**

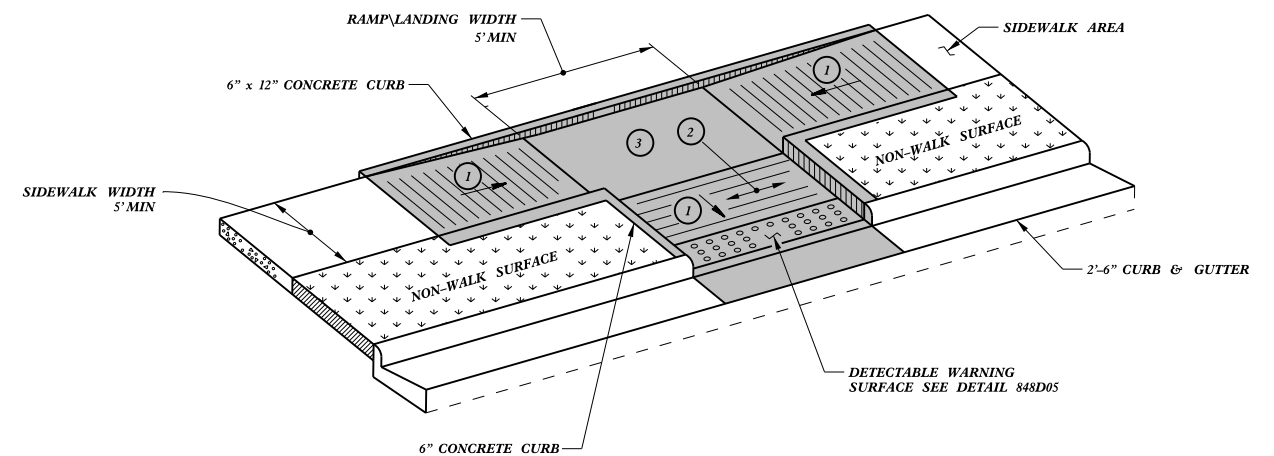

**TYPE 3**

<b>CONTRACT STANDARDS AND DEVELOPMENT UNIT</b>	
Office 919-707-6950	FAX 919-250-4119
<b>CURB RAMPS</b>	
Parallel Ramps	
ORIGINAL BY: J.S. HOWERTON	DATE: 7/7/11
MODIFIED BY:	DATE:
CHECKED BY:	DATE:
FILE SPEC: sstds/2012CurbRamp/CurbRampDetails.dwg	

REFER TO ROADWAY STANDARD DRAWING NUMBER 848.05 SHEET 3 OF 3 FOR ALL RAMP NOTES

23-MAR-2012 15:07 S:\Contracts\Special Details\Howerton\Standard Drawings\2012 Standard Drawings\Curb Ramp Details.dwg J.Howerton AT C5023750

5/14/99

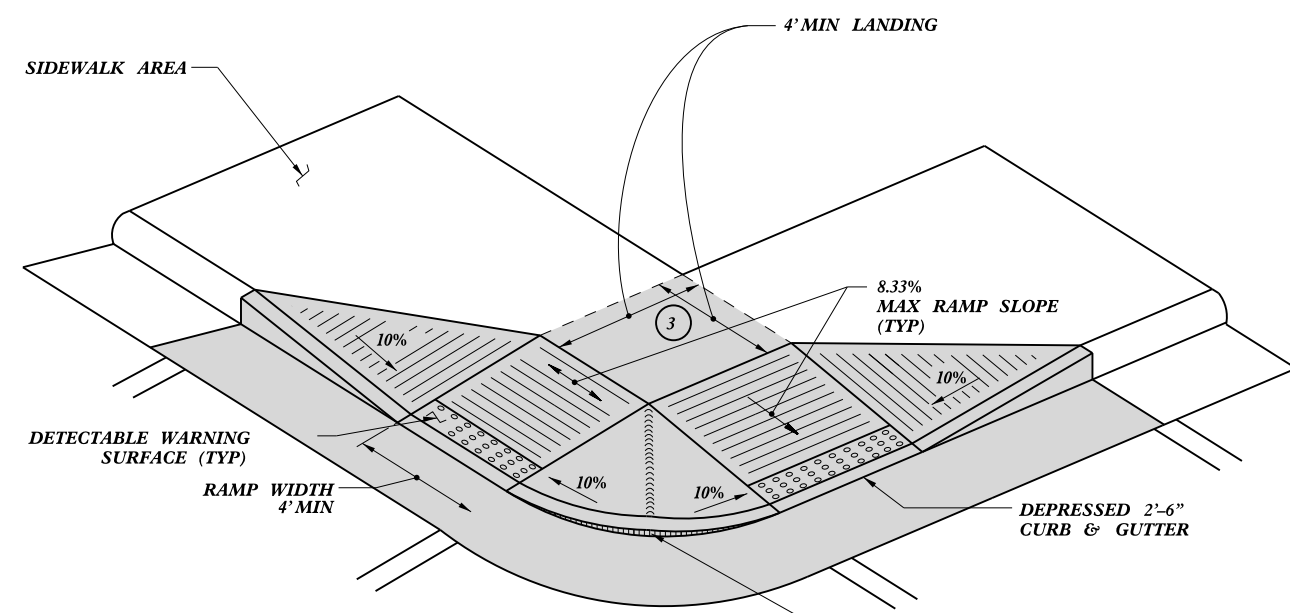

**TYPE 4**

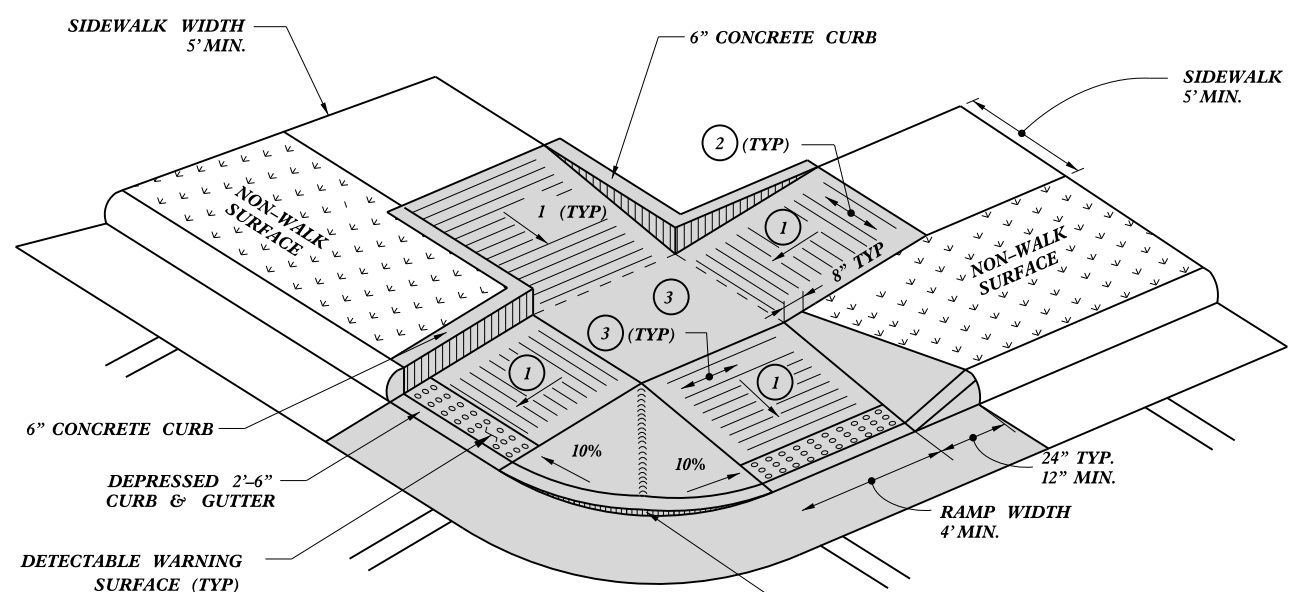

**TYPE 5**

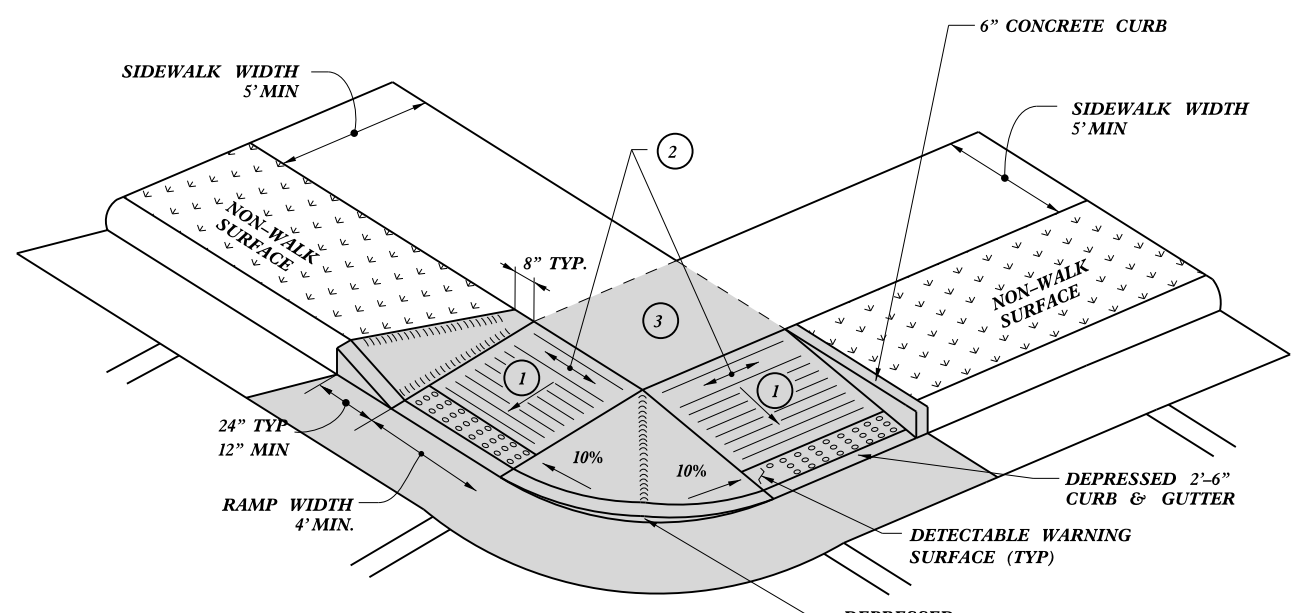

**TYPE 4A**

- 1 8.33% (12:1) MAX RAMP SLOPE
- 2 CROSS SLOPE: 2.00%
- 3 CURB RAMPS REQUIRE A (4'-0") MINIMUM LANDING WITH A MAXIMUM CROSS SLOPE AND LONGITUDINAL SLOPE OF 2.00% WHERE PEDESTRIANS PERFORM TURNING MANEUVERS. SLOPE TO DRAIN TO CURB.

PAY LIMITS FOR CURB RAMP

<b>CONTRACT STANDARDS AND DEVELOPMENT UNIT</b>	
Office 919-707-6950	FAX 919-250-4119
<b>CURB RAMPS</b>	
Shared Landing	
ORIGINAL BY: J.S. HOWERTON	DATE: 7/7/11
MODIFIED BY:	DATE:
CHECKED BY:	DATE:
FILE SPEC: sstds/2012CurbRamp/CurbRampDetails.dwg	

REFER TO ROADWAY STANDARD DRAWING NUMBER 848.05 SHEET 3 OF 3 FOR ALL RAMP NOTES

23-MAR-2012 15:08 C:\Users\jhowerton\Documents\Standard Drawings\2012 Standard Drawings\Curb Ramp Special Details\Curb Ramp Details.dwg jhowerton AT 05023750

PAY LIMITS FOR 1 CURB RAMP

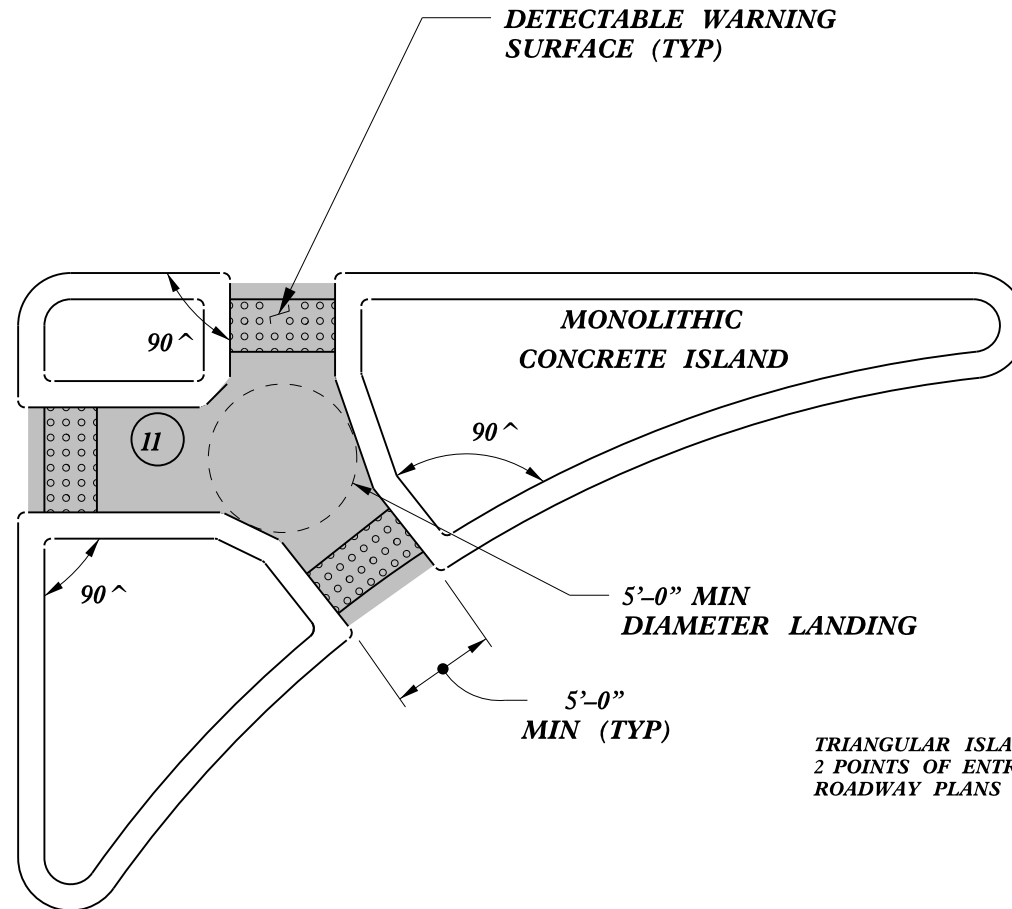

TRIANGULAR ISLANDS MAY BE CONSTRUCTED WITH ONLY 2 POINTS OF ENTRY AND EXIT AS SHOWN IN THE ROADWAY PLANS OR AS DIRECTED BY THE ENGINEER.

**TRIANGULAR ISLAND WITH CUT THROUGH**

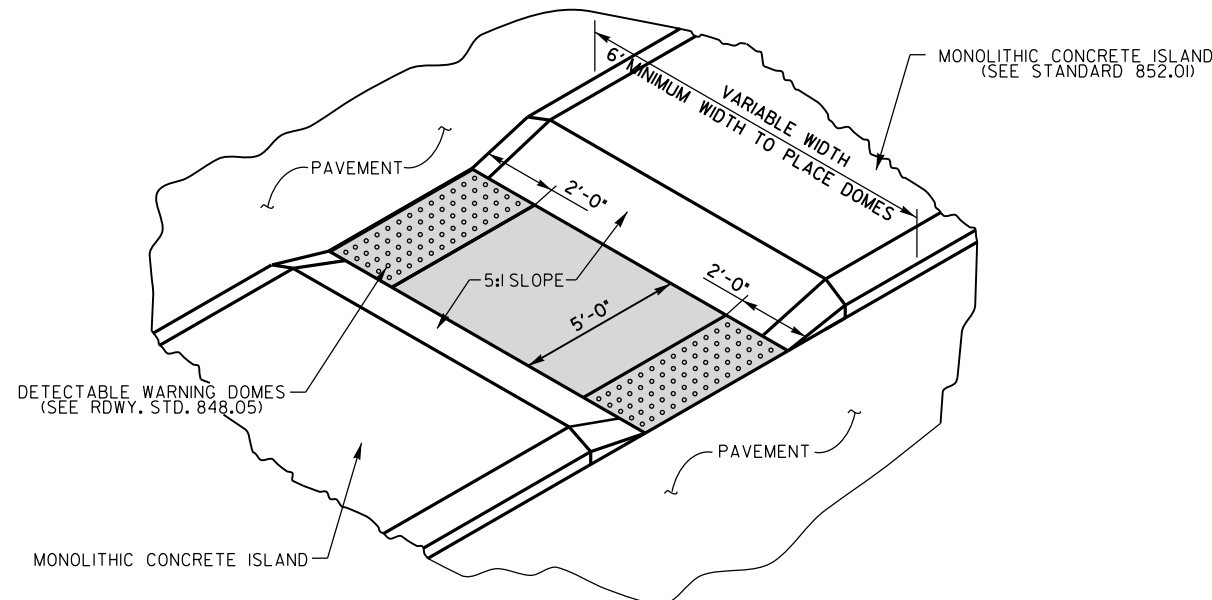

**MEDIAN ISLAND WITH CUT THROUGH**

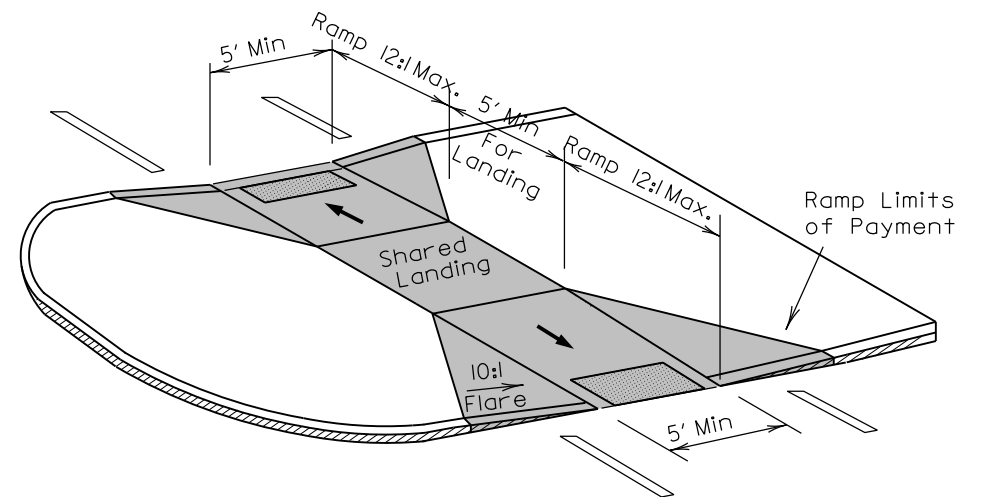

**MEDIAN ISLAND CURB RAMPS**

<b>CONTRACT STANDARDS AND DEVELOPMENT UNIT</b>	
Office 919-707-6950	FAX 919-250-4119
<b>CURB RAMPS</b>	
Median or Turn Lane Islands	
ORIGINAL BY: J.S. HOWERTON	DATE: 7/7/11
MODIFIED BY:	DATE:
CHECKED BY:	DATE:
FILE SPEC: s:\stds\2012CurbRamp\CurbRampDetails.dwg	

5/14/99  
C:\P\2012\2012CurbRamp\CurbRampDetails.dwg



PROJECT REFERENCE NO.	SHEET NO.
<i>W-5813A</i>	4
RW SHEET NO.	
ROADWAY DESIGN ENGINEER	HYDRAULICS ENGINEER
<b>DOCUMENT NOT CONSIDERED FINAL UNLESS ALL SIGNATURES COMPLETED</b>	

8/17/99  
17-MAY-2022 12:08  
S:\066\Projects\A1\DWG\330171  
C:\Users\lucifer\Documents\Projects\W-5813A\Roadway\Proj\W-5813A\_addc.psdgn  
wccatver

REVISIONS

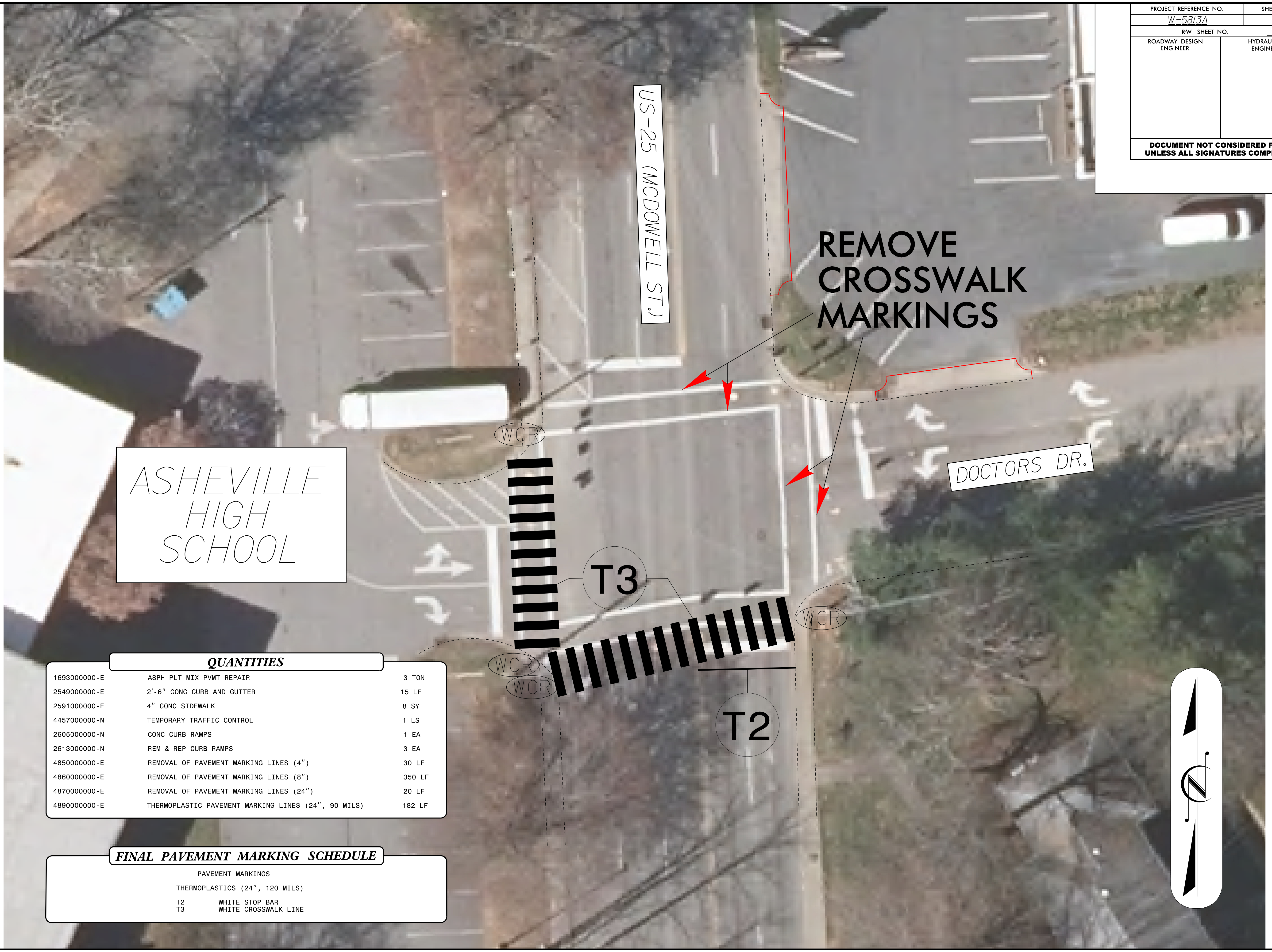

ASHEVILLE HIGH SCHOOL

US-25 (MCDOWELL ST.)

DOCTORS DR.

REMOVE CROSSWALK MARKINGS

**QUANTITIES**

1693000000-E	ASPH PLT MIX PVMT REPAIR	3 TON
2549000000-E	2'-6" CONC CURB AND GUTTER	15 LF
2591000000-E	4" CONC SIDEWALK	8 SY
4457000000-N	TEMPORARY TRAFFIC CONTROL	1 LS
2605000000-N	CONC CURB RAMPS	1 EA
2613000000-N	REM & REP CURB RAMPS	3 EA
4850000000-E	REMOVAL OF PAVEMENT MARKING LINES (4")	30 LF
4860000000-E	REMOVAL OF PAVEMENT MARKING LINES (8")	350 LF
4870000000-E	REMOVAL OF PAVEMENT MARKING LINES (24")	20 LF
4890000000-E	THERMOPLASTIC PAVEMENT MARKING LINES (24", 90 MILS)	182 LF

**FINAL PAVEMENT MARKING SCHEDULE**

PAVEMENT MARKINGS	
	THERMOPLASTICS (24", 120 MILS)
T2	WHITE STOP BAR
T3	WHITE CROSSWALK LINE

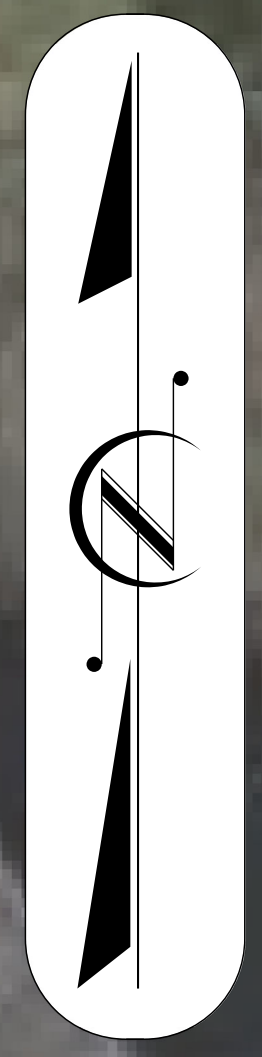

T3

T2

WCR

WCR

WCR

WCR



PHASING DIAGRAM

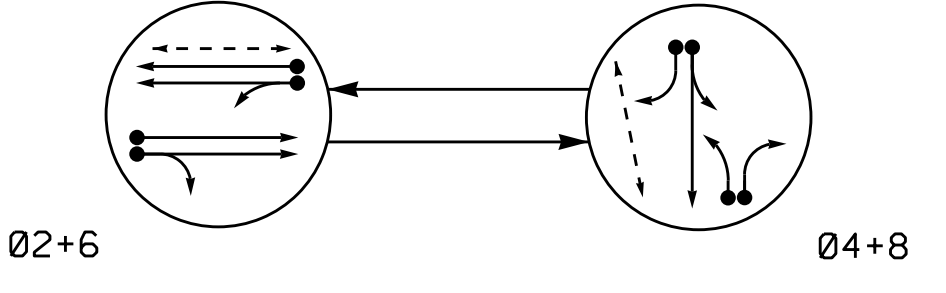

PHASING DIAGRAM DETECTION LEGEND  
 ● DETECTED MOVEMENT  
 ◄ UNDETECTED MOVEMENT (OVERLAP)  
 - - - UNSIGNALIZED MOVEMENT  
 <- - - PEDESTRIAN MOVEMENT

TABLE OF OPERATION

SIGNAL FACE	PHASE		
	02+6	04+8	F.L. LOCAL HEADS
21,22	G	R	Y
41,42	R	G	R
61,62	G	R	Y
81,82	R	G	R
P41,P42	DW	W	DRK
P61,P62	W	DW	DRK

OASIS 2070 LOOP & DETECTOR INSTALLATION CHART

LOOP	SIZE (FT)	DISTANCE FROM STOPBAR (FT)	TURNS	NEW LOOP	DETECTOR PROGRAMMING						SYSTEM LOOP NEW CARD	
					PHASE	CALLING	EXTENSION	FULL TIME DELAY	STRETCH TIME	DELAY TIME		
2A	6X17	61	4	-	2	Y	Y	-	-	-	-	-
4A	6X17	2	3	-	4	Y	Y	-	-	5	-	-
6A	6X16	70	3	-	6	Y	Y	-	-	-	-	-
8A	6X60	+5	2-4-2	-	8	Y	Y	-	-	3	-	-
8B	6X60	+5	2-4-2	-	8	Y	Y	-	-	10	-	-

2 Phase Fully Actuated Asheville Signal System

NOTES

- Refer to "Roadway Standard Drawings NCDOT" dated January 2018 and "Standard Specifications for Roads and Structures" dated January 2018.
- Do not program signal for late night flashing operation unless otherwise directed by the Engineer.
- Set all detector units to presence mode.
- In the event of loop replacement, refer to the current ITS and Signals Design Manual and submit a Plan of Record to the Signal Design Section.
- Omit "WALK" and flashing "DON'T WALK" with no pedestrian calls.
- Program pedestrian heads to countdown the flashing "Don't Walk" time only.
- Maximum times shown in timing chart are for free-run operation only. Coordinated signal system timing values supersede these values.

SIGNAL FACE I.D.

All Heads L.E.D.

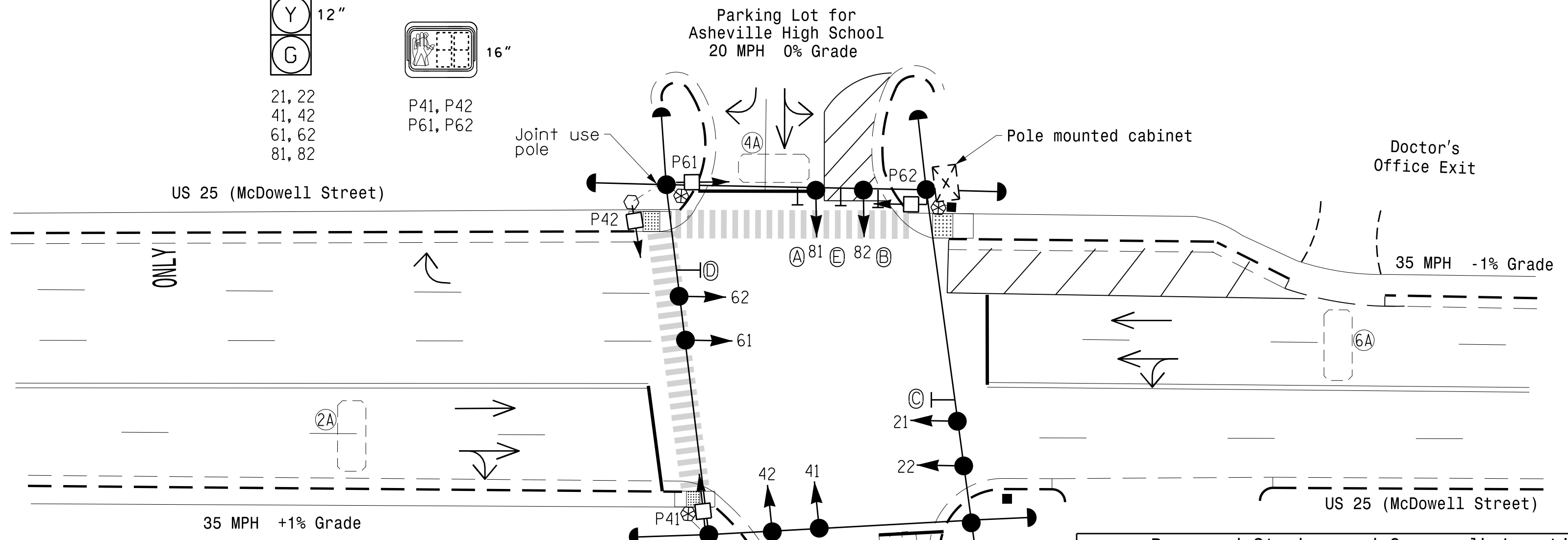
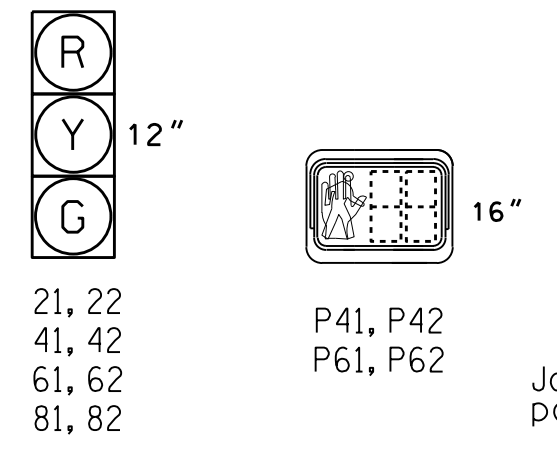

LEGEND

PROPOSED	EXISTING
○	●
◐	◑
↓	↓
⊙	⊙
⊞	⊞
⊚	⊚
⊛	⊛
⊜	⊜
⊝	⊝
⊞	⊞
⊟	⊟
⊠	⊠
⊡	⊡
⊢	⊢
⊣	⊣
⊤	⊤
⊥	⊥
⊦	⊦
⊧	⊧
⊨	⊨
⊩	⊩
⊪	⊪
⊫	⊫
⊬	⊬
⊭	⊭
⊮	⊮
⊯	⊯
⊰	⊰
⊱	⊱
⊲	⊲
⊳	⊳
⊴	⊴
⊵	⊵
⊶	⊶
⊷	⊷
⊸	⊸
⊹	⊹
⊺	⊺
⊻	⊻
⊼	⊼
⊽	⊽
⊾	⊾
⊿	⊿
⋈	⋈
⋉	⋉
⋊	⋊
⋋	⋋
⋌	⋌
⋍	⋍
⋎	⋎
⋏	⋏
⋐	⋐
⋑	⋑
⋒	⋒
⋓	⋓
⋔	⋔
⋕	⋕
⋖	⋖
⋗	⋗
⋘	⋘
⋙	⋙
⋚	⋚
⋛	⋛
⋜	⋜
⋝	⋝
⋞	⋞
⋟	⋟
⋠	⋠
⋡	⋡
⋢	⋢
⋣	⋣
⋤	⋤
⋥	⋥
⋦	⋦
⋧	⋧
⋨	⋨
⋩	⋩
⋪	⋪
⋫	⋫
⋬	⋬
⋭	⋭
⋮	⋮
⋯	⋯
⋰	⋰
⋱	⋱
⋲	⋲
⋳	⋳
⋴	⋴
⋵	⋵
⋶	⋶
⋷	⋷
⋸	⋸
⋹	⋹
⋺	⋺
⋻	⋻
⋼	⋼
⋽	⋽
⋾	⋾
⋿	⋿
⌞	⌞
⌟	⌟
⌠	⌠
⌡	⌡
⌢	⌢
⌣	⌣
⌤	⌤
⌥	⌥
⌦	⌦
⌧	⌧
⌨	⌨
〈	〈
〉	〉
⌫	⌫
⌬	⌬
⌭	⌭
⌮	⌮
⌯	⌯
⌰	⌰
⌱	⌱
⌲	⌲
⌳	⌳
⌴	⌴
⌵	⌵
⌶	⌶
⌷	⌷
⌸	⌸
⌹	⌹
⌺	⌺
⌻	⌻
⌼	⌼
⌽	⌽
⌾	⌾
⌿	⌿

OASIS 2070 TIMING CHART

FEATURE	PHASE			
	2	4	6	8
Min Green 1 *	10	7	10	7
Extension 1 *	3.0	2.0	3.0	2.0
Max Green 1 *	50	25	50	25
Yellow Clearance	3.9	3.0	3.9	3.0
Red Clearance	1.3	2.3	1.3	2.3
Red Revert	2.0	2.0	2.0	2.0
Walk 1 *	-	7	7	-
Don't Walk 1	-	13	10	-
Seconds Per Actuation *	-	-	-	-
Max Variable Initial *	-	-	-	-
Time Before Reduction *	-	-	-	-
Time To Reduce *	-	-	-	-
Minimum Gap	-	-	-	-
Recall Mode	MIN RECALL	-	MIN RECALL	-
Vehicle Call Memory	YELLOW	-	YELLOW	-
Dual Entry	-	ON	-	ON
Simultaneous Gap	ON	ON	ON	ON

\* These values may be field adjusted. Do not adjust Min Green and Extension times for phases 2 and 6 lower than what is shown. Min Green for all other phases should not be lower than 4 seconds.

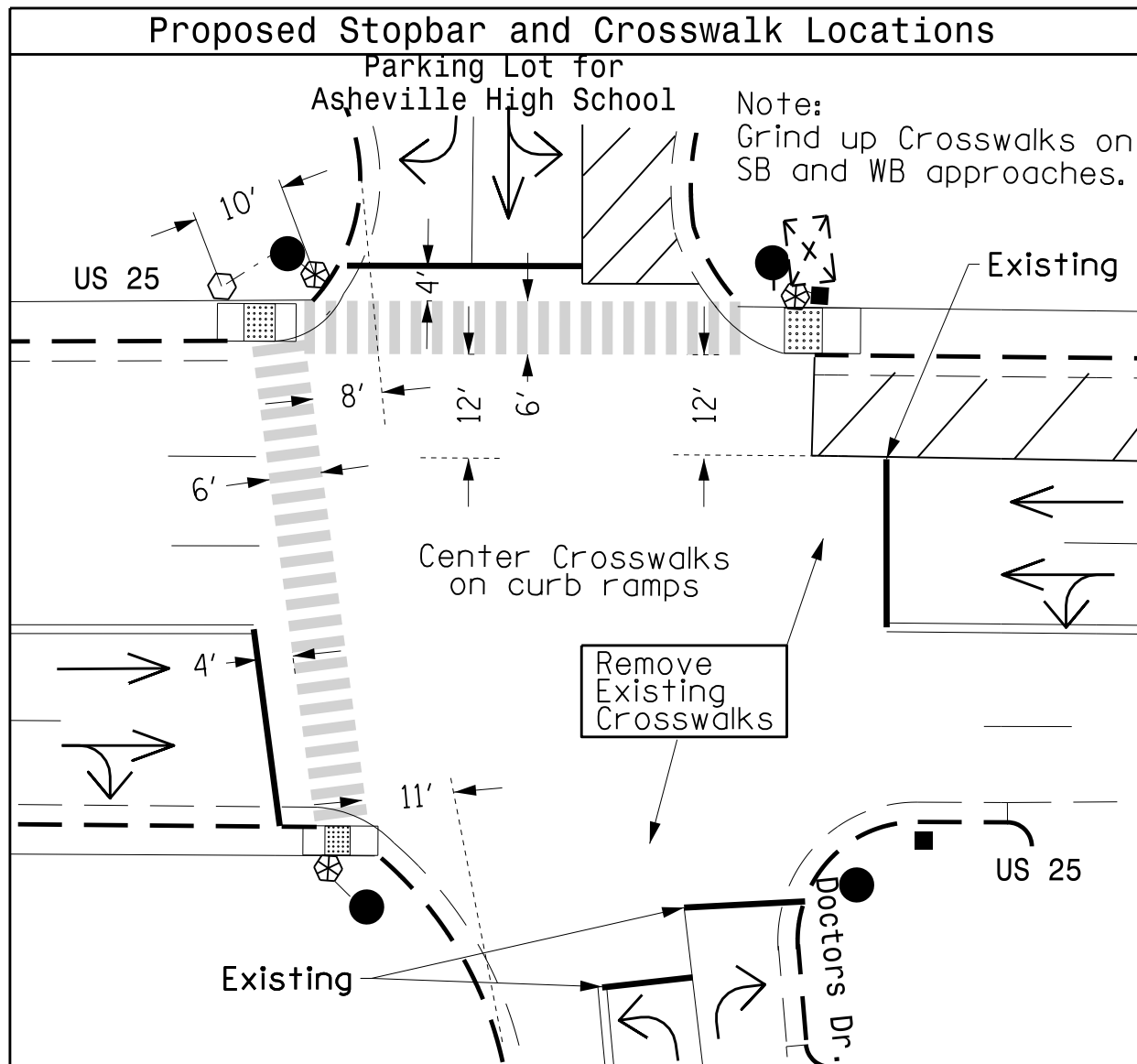

Signal Upgrade

Prepared In the Offices of:  

 TRANSPORTATION MOBILITY AND SAFETY DIVISION  
 DIVISION OF TRANSPORTATION  
 SIGNAL DESIGN SECTION  
 750 N. Greenfield Pkwy, Garner, NC 27529

US 25 (McDowell Street)  
 at  
 Doctors Drive / Asheville HS  
 Division 13 Buncombe County Asheville  
 PLAN DATE: February 2021 REVIEWED BY: T.J. Williams  
 PREPARED BY: EM Minshew REVIEWED BY:  
 REVISIONS INIT. DATE  
 SCALE 0 20  
 1"=20'

DOCUMENT NOT CONSIDERED FINAL UNLESS ALL SIGNATURES COMPLETED

SEAL  
 NORTH CAROLINA PROFESSIONAL ENGINEER  
 SEAL 024393  
 T.MOOTHY J. WILLIAMS  
 DocuSigned by:  
 T. J. Williams 3/23/2021  
 DATE  
 SIG. INVENTORY NO. 13-0066

**EDI MODEL 2018EClip-NC CONFLICT MONITOR PROGRAMMING DETAIL**

(remove jumpers and set switches as shown)

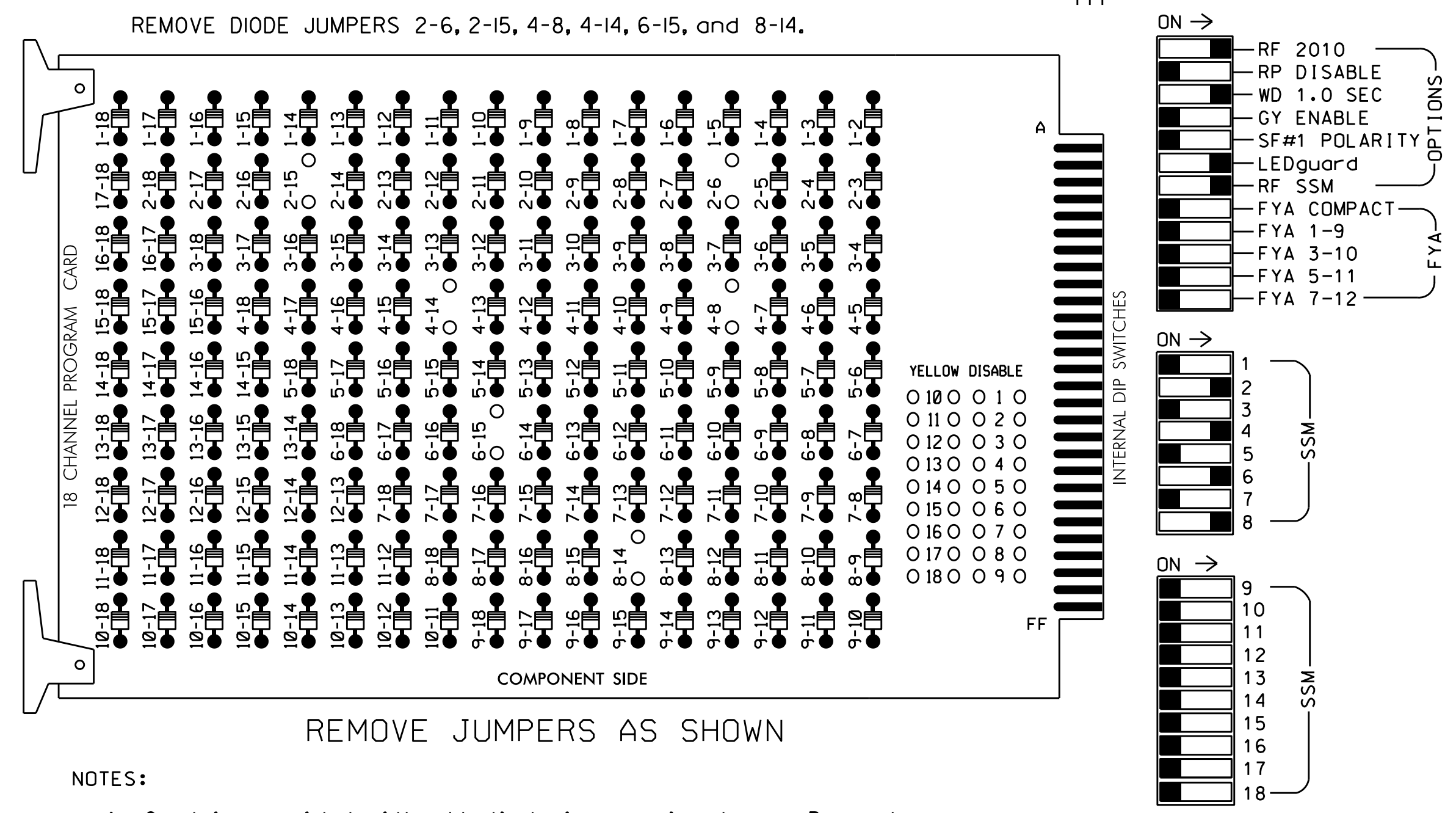

**NOTES:**

1. Card is provided with all diode jumpers in place. Removal of any jumper allows its channels to run concurrently.
2. Ensure jumpers SEL2-SEL5 and SEL9 are present on the monitor board.
3. Ensure that Red Enable is active at all times during normal operation.
4. Integrate monitor with Ethernet network in cabinet.

**NOTES**

1. To prevent "flash-conflict" problems, insert red flash program blocks for all unused vehicle load switches in the output file. The installer shall verify that signal heads flash in accordance with the Signal Plans.
2. Program phases 4 and 8 for Dual Entry.
3. Enable Simultaneous Gap-Out for all phases.
4. Program phases 2 and 6 for Start Up In Green.
5. Program phases 4 and 6 for Startup Ped Call.
6. Program phases 2 and 6 for Yellow Flash.
7. The cabinet and controller are part of the Asheville Signal System.

**EQUIPMENT INFORMATION**

CONTROLLER.....2070E  
 CABINET.....336  
 SOFTWARE.....ECONOLITE OASIS  
 CABINET MOUNT.....POLE  
 OUTPUT FILE POSITIONS...12  
 LOAD SWITCHES USED.....S2,S5,S6,S8,S9,S11  
 PHASES USED.....2,4,4PED,6,6PED,8  
 OVERLAPS.....NONE

**SIGNAL HEAD HOOK-UP CHART**

LOAD SWITCH NO.	S1	S2	S3	S4	S5	S6	S7	S8	S9	S10	S11	S12
CMU CHANNEL NO.	1	2	13	3	4	14	5	6	15	7	8	16
PHASE	1	2	2 PED	3	4	4 PED	5	6	6 PED	7	8	8 PED
SIGNAL HEAD NO.	NU	21,22	NU	NU	41,42	P41, P42	NU	61,62	P61, P62	NU	81,82	NU
RED		128			101			134			107	
YELLOW		129			102			135			108	
GREEN		130			103			136			109	
RED ARROW												
YELLOW ARROW												
GREEN ARROW												
Hand icon						104			119			
Walker icon						106			121			

NU = Not Used

**COUNTDOWN PEDESTRIAN SIGNAL OPERATION**

Countdown Ped Signals are required to display timing only during Ped Clearance Interval. Consult Ped Signal Module user's manual for instructions on selecting this feature.

**INPUT FILE POSITION LAYOUT**

(front view)

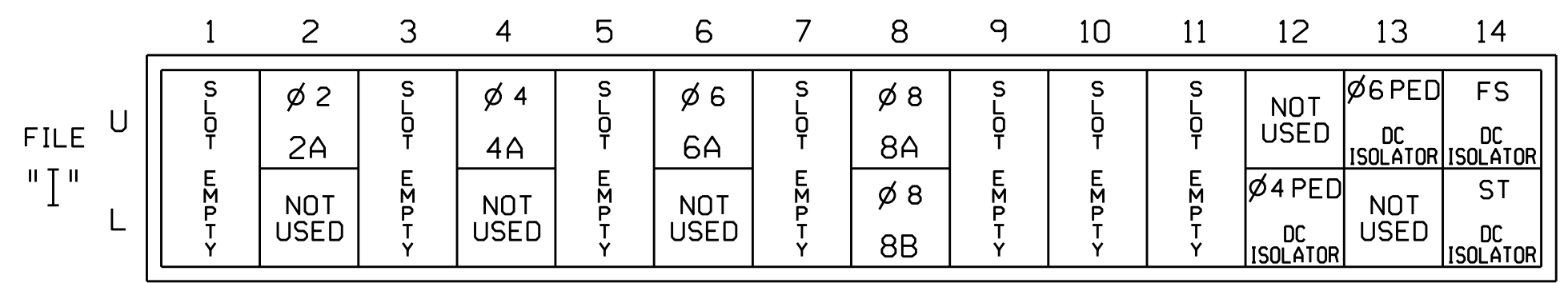

EX. : 1A, 2A, ETC. = LOOP NO.'S

FS = FLASH SENSE  
 ST = STOP TIME

**INPUT FILE CONNECTION & PROGRAMMING CHART**

LOOP NO.	LOOP TERMINAL	INPUT FILE POS.	PIN NO.	INPUT ASSIGNMENT NO.	DETECTOR NO.	NEMA PHASE	CALL	EXTEND	FULL TIME DELAY	STRETCH TIME	DELAY TIME
2A	TB21-3,4	I2U	39	1	2	2	Y	Y			
4A	TB21-7,8	I4U	41	3	4	4	Y	Y			5
6A	TB21-11,12	I6U	40	2	6	6	Y	Y			
8A	TB22-1,2	I8U	42	4	8	8	Y	Y			3
8B	TB24-1,2	I8L	46	8	18	8	Y	Y			10
PED PUSH BUTTONS											
P41,P42	TB24-9,10	I12L	69	31		PED 4		4 PED			
P61,P62	TB22-11,12	I13U	68	30		PED 6		6 PED			

NOTE:  
 INSTALL DC ISOLATORS IN INPUT FILE SLOTS I12 AND I13.

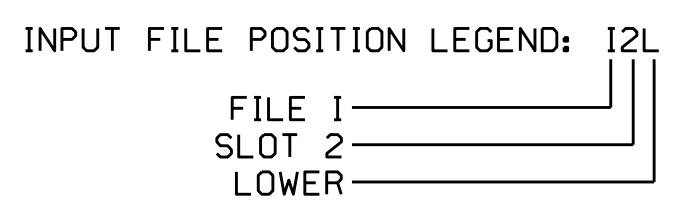

THIS ELECTRICAL DETAIL IS FOR THE SIGNAL DESIGN: 13-0066  
 DESIGNED: February 2021  
 SEALED: 3/23/2021  
 REVISED: N/A

24-MAR-2021 11:16 S:\IT\SAS\13\Sig Management\Projects\3-0066.dwg Project:30066.sm.ele...xx.dgn  
 S:\IT\SAS\13\Sig Management\Projects\3-0066.dwg Project:30066.sm.ele...xx.dgn  
 S:\IT\SAS\13\Sig Management\Projects\3-0066.dwg Project:30066.sm.ele...xx.dgn

Electrical Detail

Prepared In the Offices of:

750 N. Greenfield Pkwy, Garner, NC 27529

US 25 (McDowell Street) at Doctors Drive/Asheville HS

Division 13 Buncombe County Asheville

PLAN DATE: March 2021 REVIEWED BY:

PREPARED BY: S. Armstrong REVIEWED BY:

REVISIONS INIT. DATE

DocuSigned by: Ryan W. Hough 3/25/2021

SIG. INVENTORY NO. 13-0066

DOCUMENT NOT CONSIDERED FINAL UNLESS ALL SIGNATURES COMPLETED

SEAL

RYAN W. HOUGH

ENGINEER

036833